

CP400 Rope Cocking Sled Instructions

The CP400 uses a rope cocking sled that is different than the traditional two hook design as found with previous crossbow models from CenterPoint Archery. This “sled” is designed exclusively for the CP400 and is designed to fit under the riser bridge of the CP400 crossbow. Review and understand the diagrams and instructions as shown in **Section 6C, Cocking Procedures**, of your CP400 owner’s manual prior to cocking the crossbow.

The CP400 cocking sled has two string grooves that must be fully engaged on the bow string at all times during the cocking process (**See Section 6C, Fig. 17**). The string grooves on the cocking sled allow the string to be drawn in an even, torque free manner allowing the CP400 crossbow to be smoothly cocked.

CAUTION: Always make sure both string grooves of the sled are engaged on the string during the cocking process. Failure to engage both string grooves may cause damage to the sled, the crossbow and/or cause injury to the user.

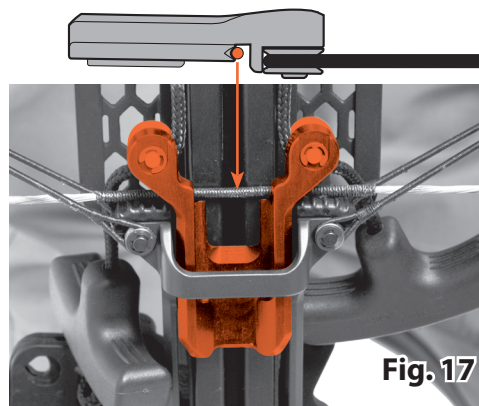

Fig. 17

CAUTION: In addition to having the sled seated correctly with both string grooves fully engaged on the string, make sure that the rope is seated in the groove on the stock as shown in **Section 6C, Fig. 16**. Make sure that the rope is parallel to the rail and the rope runs unobstructed from the rope groove to the pulley wheel on the sled. Failure to make sure that rope runs unobstructed, may cause damage to the sled, the crossbow and/or cause injury to the user.

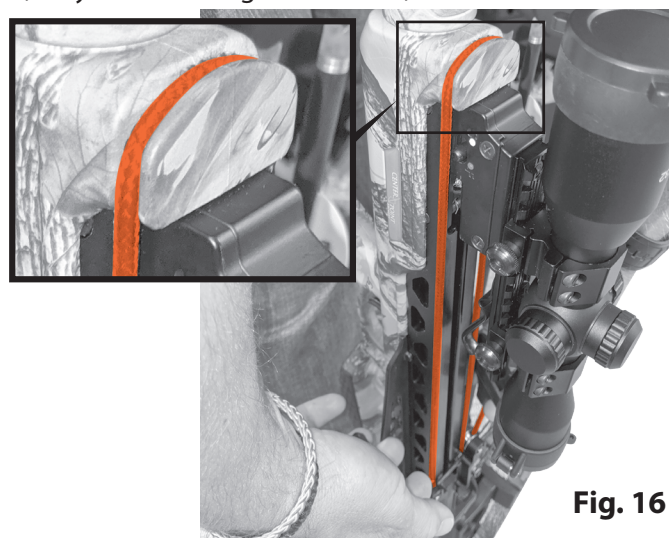

Fig. 16

For instructional video on how to use the CP400 rope cocker sled visit, centerpointarchery.com/CP400SLED. For customer service assistance, please contact CenterPoint Archery Customer Service at 715-718-3574.